

QUO VADIS : Low Temperature Calorimetry

Hiroshi Suga

*Research Institute for Science and Technology, Kinki University
Kowakae, Higashi-Osaka 577-8502, Japan*

(Received, October 16, 2000)

Abstract

Low temperature heat capacity calorimetry has a long history in the field of chemical thermodynamics in relation to the third law of thermodynamics. The method is playing an important role in the recent materials science. Central research subject has been shifted according to the need and fashion of the times. The calorimetry has been used in static as well as dynamic modes. By surveying the historical development of the low temperature calorimetry, several suggestions to new directions in the instrumentations and research subjects are described in this article.

Key words: adiabatic calorimetry, heat capacity, phase transition, glass transition, low-frequency spectrometer, glassy solids

1. Introduction

Research subject and instrument for the measurement constitute a pair of wheels of a wagon. Both sides of the wheel must keep a good balance in movement to have a good performance of the wagon. To develop a good apparatus is prerequisite for producing high quality data. Only intriguing discussions based on the reliable data will attract many scientists. Here I would like to follow the historical development of low

temperature calorimetry from the above two aspects and try to search some novel directions to which we must proceed in the coming new century. As a matter of convenience, calorimetry above 13 K is discussed first. The description is followed by that at cryogenic temperatures. The rather biased topics taken up here are due to our limited experiences.

2. Adiabatic calorimetry

2.1. Historical survey of research subjects

Low temperature calorimetry has been developed to a highly sophisticated level and is believed to produce the most accurate and precise heat capacity data. There are several reasons for that. The first is the experimental verification of

the heat theorem proposed by Nernst who postulated that the entropy difference between any reversible processes involving crystalline substances vanishes as the temperature approaches zero. The theorem was reformulated later in a statement that the entropy of each crystalline solid

becomes zero at 0 K if the system is in internal equilibrium. This bold proposal has received various experimental tests [1]. Among many methods, the most quantitative and reliable way is to compare the calorimetrically determined entropy of a substance in an ideal gas state, $S^\circ_T(g) - S^\circ_0(cr)$, with the spectroscopically determined entropy of the same substance in the same state $S^\circ_T(g)$. If both the quantities agree each other within experimental uncertainty, it can be concluded that $S^\circ_0(cr)=0$. The experiments were done most extensively by Giauque and his collaborators and resulted in great improvement in the accuracy and precision of the heat capacity data. The entropy is only one thermodynamic function that can have absolute value thanks to the third law of thermodynamics. Obviously, this law requires the establishment of internal equilibrium in any crystalline solids.

The second is the successful explanation for the heat capacity of solid approaching zero as the temperature is lowered. This was done by Einstein through quantization of the lattice-vibrational motion. Debye improved the theory by taking into account the effect of distribution of the vibrational frequencies on the heat capacity. Lattice dynamical calculation of the frequency spectra of crystalline solids required great improvement of the heat capacity data [2]. Since the frequency spectra can be obtained in principle by a Fourier transformation of the heat capacity, small error in the experimental data particularly at low temperatures resulted in a large deformation of the spectra at high-frequency region.

The third is the phase transition phenomena occurring in crystals [3]. The transition modified slightly or drastically some physical properties of the crystal such as electric, magnetic, mechanical, optical, and others. The sudden drop of the heat capacity observed by Keesom at the superconducting transition of Sn metal attracted many theoreticians as well as experimentalists to take systematic study on various types of the phase transition including ferromagnetic-paramagnetic, ferroelectric-paraelectric, ferroelastic-paraelastic transitions, positional order-disorder transition in binary alloy *etc.* In this way, a new field of materials science has started since the early 1960s. Among various techniques for the research, the low temperature calorimetry was one of the best

methods because the experiment can be done under a good thermal stability with continuous confirmation of the thermal equilibrium. Also the method is only the way to provide the information of entropy change accompanied by the transition. The amount can be discussed by the increase in disorder through the Boltzmann' equation $k \ln W$, where W is the complexion or the number of microscopically accessible states. Obviously X-ray structural analyses below and above the transition temperature T_{trs} helped much to deepen the understanding of the nature of transition.

Many features of some superconducting, superfluid, magnetic, and electric transitions are quite similar to those found in the liquid-vapor critical points. There must be a common physical basis under the seemingly different phenomena. Study on critical phenomena in crystals required specifically very high temperature stability and resolution in order to obtain critical indices from the behavior of heat capacity divergence at temperatures very close to critical temperature T_c . Readers can refer many pioneering works that have been done in the early 1960s. Excellent works on liquid He and several magnetic systems are summarized in two review articles [4,5]. In the case of $\text{SnCl}_2 \cdot 2\text{H}_2\text{O}$ dielectric crystal [6], a highly symmetrical heat-capacity divergence around $T_c = 218.01$ K was observed for a high-quality single crystal and the critical indices were obtained from the heat capacity data measured with the temperature resolution of 5 μK . Possible effect of deuteration on the nature of the transition was examined extensively. A typical experimental result is drawn in Fig. 1. The symmetrical divergence was taken as a trademark of two-dimensionally interacting system. These results on liquid He, as well as magnetic and dielectric crystals stimulated theoreticians to open a new realm of critical phenomena in the statistical thermodynamics [7]. It turned out that fluctuation in physical quantities such as density and entropy plays an important role in the phenomena, as in the case of critical opalescence observed at the liquid-vapor critical point.

The heat capacity is defined thermodynamically as follows

$$C_p = T(\partial S / \partial T)_p = -T(\partial^2 G / \partial T^2)_p \quad (1)$$

Thus the heat capacity data can be manipulated to derive standard thermodynamic functions such as

the enthalpy increment $H_T^\circ - H_0^\circ$, the entropy increment $S_T^\circ - S_0^\circ$, and the Gibbs energy increment $G_T^\circ - H_0^\circ$ as a function of temperature. The numerical values at selected temperature, conventionally at 298.15 K, have been compiled in many databooks and databases and used to calculate the thermodynamic equilibrium constant of any chemical reactions. This has been one of the central problems in chemical thermodynamics from the early stage of development. The calculation was very important in designing chemical plant in order to find out the best condition for the highest efficiency in the production. In minimizing the energy loss, it is very important to calculate the equilibrium constant as accurately as possible based on high-quality thermodynamic data.

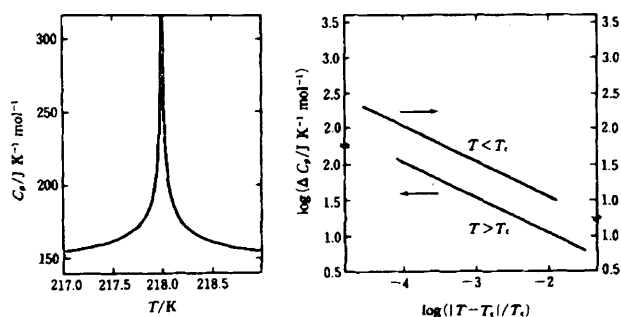

Figure 1 (left) Heat capacity divergence at critical temperature T_c and (right) critical plot of $\text{SnCl}_2 \cdot 2\text{H}_2\text{O}$ single crystal.

About 19,000,000 substances have been registered nowadays in the Chemical Abstracts Service and the number is increasingly rapidly. Each substance has their own thermodynamic quantities as a particular function of temperature. In view of the huge number of substances, however, we are forced to measure only thermodynamic functions of selected key substances or industrially important substances. In surveying databases, it will be noticed immediately that the number of data for the standard entropy S° is much smaller than the data for the standard enthalpy of formation $\Delta_f H^\circ$. Both the data are equally important in determining any chemical equilibria. This situation will give to low temperature calorimetrists a strong driving force for extending their measurements to the substances of which the thermochemical data have been published already.

2.2. Development of instrumentation

In 1968, the IUPAC I.2 Commission of Thermodynamics and Thermochemistry has published a monograph [8] entitled "Experimental Thermodynamics, Vol. I, Calorimetry of Non-reacting System". Three chapters were devoted to the construction and operation of the low temperature calorimeter with discontinuous heating mode. At that times, this method has been accepted as one of the most hardest and time-consuming experimental techniques. At least, two scientists should be engaged cooperatively in the measurement. The one must concentrate in the adiabatic control all the times, and the other in the energy measurement during energizing period and in the temperature measurement during equilibration period. There was no apparatus commercially available. Scientists must start from the designing of the apparatus suitable for the object. They were embarrassed occasionally by vacuum leakage that damages the realization of adiabatic condition. Improvement in the quality of constructing materials and sealing as well as welding techniques helped them to be free from leakage problem.

The hard works were saved greatly by the rapid development of various electronic devices. Particularly, production of high quality PID controller developed around 1960s was sufficient enough to eliminate one of the operators from the measurement. Traditional potentiometer was replaced progressively by a digital voltmeter with a precision of $\pm 0.1 \mu\text{V}$. Development of personal computer made it possible to combine organically these electronic devices to operate the whole system following to a predetermined program. Thus the second operator has ultimately lost the job. A fully automated apparatus was published in 1957 by Stull [9] in analog mode and in 1972 by Martin [10] in digital mode. Inspired by these pioneering works, we have developed an on-line automated adiabatic calorimeter [11]. These apparatuses work day and night without intermission and are helpful in shortening the experimental period. The on-line data acquisition system immediately give us the heat capacity data during the measurement. If we observe some anomalous behavior in the heat capacity, we can make another set of measurement before dismantling the apparatus.

The low temperature adiabatic calorimeter has

traditionally used a sample of about 30 - 80 g, or more in some cases, in order to have highly accurate data. As a particular case, Burk *et al.* [12] have used about 100 g of expensive diamond sample in determining its entropy by virtue of the high Debye temperature of the sample. Generally it is not easy to prepare a high-purity sample in large quantity. Westrum has pointed out already in 1972 the importance of development of adiabatic calorimeter for small samples [13]. Thus miniaturization of the calorimeter has been tried by many scientists. One of the miniaturized calorimeters developed by us [14] is drawn schematically in Fig. 2. In this twin-type calorimeter, the sample cell has only an electric heater for energizing. The second cell made of a copper block has a heater and a working resistance thermometer. Temperature difference between the two cells is monitored by a pair of fine thermocouples and any deviation signal is fed into the heater of the latter after power amplification so as to keep always the same temperature. Thus the temperature of the sample cell is transferred to the second cell and its temperature is measured by the standard thermometry. This method reduces greatly the heat capacity of the sample cell and unavoidable self-heating effect associated with the thermometry. The microcalorimeter has been used to measure successfully the heat capacities of C_{60} [15] and protein [16] crystals by using several hundreds mg samples while keeping essentially the

same accuracy and precision with those of one-generation older apparatus that required 2 - 4 g sample. Obviously it is desirable to reduce the necessary amount of sample without loss of general accuracy. A dream of constructing a nano-calorimeter will be realized if the surrounding devices are greatly improved in a future. Thus the miniaturization of calorimeter is an eternal theme in thermodynamics, as in the cases of other fields of science.

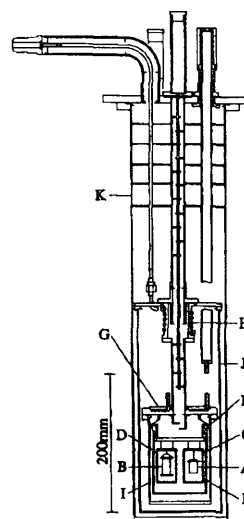

Figure 2 Twin-type adiabatic microcalorimeter. A, sample cell ; B, thermometric block : C and D, inner adiabatic shields : E, outer shield ; F, thermal anchor ; G and H, heat exchangers : I, inner vacuum can : J, radiation shield : K, outer vacuum can

3. Perspectives of heat capacity calorimetry

3.1. Study of dynamic properties

So far, the adiabatic calorimeter has been used to measure the heat capacity as a static equilibrium property of a substance. Actually we are measuring the enthalpy of a sample as a function of temperature, and the average heat capacity is calculated by the ratio between the enthalpy increment and the temperature increment.

$$C_p = \Delta H / \Delta T = E / \Delta T \quad (2)$$

where E is a supplied electric energy at constant pressure and ΔT is the resulting temperature rise. Establishment of thermal equilibrium is confirmed always by observing constancy of the calorimetric temperature with time during every equilibration periods.

We encounter sometimes a spontaneous temperature change of sample during equilibration period. This happens typically around the glass transition temperature T_g of a liquid and the spontaneous change in calorimetric temperature arises from irreversible stabilization of liquid structure that has frozen during cooling of the sample. At T_g , the heat capacity decreases rapidly over a small temperature interval. Below T_g , the heat capacity is largely due to the vibrations of a disordered solid called glass, whereas above T_g , the changing structure of the liquid also contributes to the heat capacity. The latter part is called the configurational heat capacity and the corresponding enthalpy is designated as the configurational

enthalpy H_c .

Heat capacity and entropy of isopropylbenzene are drawn in Fig. 3 as a function of temperature [17]. It is important to note that the heat capacity is determined by extrapolating the temperature drifts to the mid-point of energizing period in determining the initial and final temperature ($\Delta T = T_f - T_i$). Thus the derived data correspond to the "instantaneous" or "iso-configurational" or "vibrational" heat capacity, as is described soon. The primary or α glass transition occurs at 126 K with a large heat capacity jump. Thus the configurational heat capacity is as large as that arising from lattice vibrations. Another small heat-capacity increase with relaxational nature was observed to occur at about 70 K. Exothermic followed by endothermic spontaneous temperature changes were observed during equilibration periods. Average rate of the temperature change dT/dt observed in the initial 20 min is plotted in Fig. 4 as a function of temperature. This is typical behavior displayed by frozen-in disordered system, and the behavior was assigned to be due to the secondary or β glass transition. The corresponding spontaneous change in calorimetric temperature around the primary T_g is much greater than this secondary glass transition. Thus the adiabatic calorimeter with a good adiabatic condition can detect sensitively any irreversible relaxation processes occurring in glasses [18].

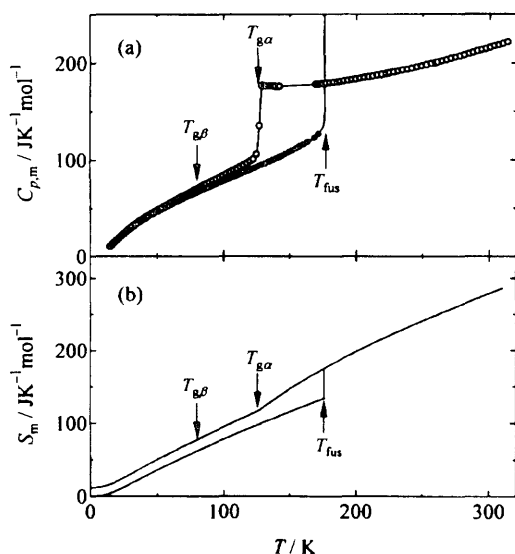

Figure 3 Heat capacity of isopropylbenzene. $T_{g\alpha}$ and $T_{g\beta}$ are primary and secondary glass transitions of the liquid.

Vibrational degrees of freedom can respond quickly to the change in external intensive variables. On the other hand, the response time of configurational enthalpy H_c increases rapidly as the temperature is lowered. The relaxation rate of H_c can be described by the empirical equation proposed by Kohlrausch, Williams and Watts [19].

$$\Delta H_c(t) = \Delta H_c(0) \exp[(-t/\tau)^\beta] \quad (3)$$

The quantity β is a parameter representing a non-exponential nature of the relaxation. The value of β is in the range $0.5 < \beta < 0.9$ in most of liquids and the relaxation function is said to be characterized by a distribution of relaxation times [20].

Since $H_c + H_{vib} = H_{total}$ of any system can be kept constant under adiabatic condition, it follows

$$\begin{aligned} d(\Delta H_c)/dt &= - [d(\Delta H_{vib})/dT][dT/dt] \\ &= - C_{vib} [dT/dt] \end{aligned} \quad (4)$$

Combination of Eqs. (3) and (4) gives the following equation.

$$T_{vib}(t) = a + bt + c \exp[(-t/\tau)^\beta] \quad (5)$$

where the second term bt represents temperature drift due to a residual heat leakage that is unavoidable for the dissipative nature of heat. In this way, analysis of the rate of spontaneous change in calorimetric temperature gives the data of τ and β as a function of temperature.

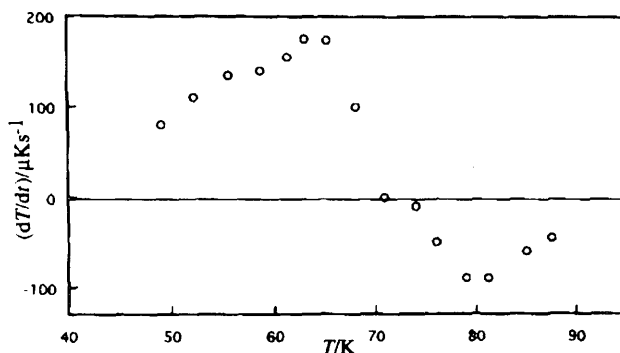

Figure 4 Spontaneous temperature drift rates observed for isopropylbenzene around its secondary (β) glass transition.

The heat capacity is a frequency-dependent quantity, as in the case of dielectric permittivity and magnetic susceptibility. By applying a sinusoidally-modulated heating, the dependence of heat capacity on the frequency and associated dynamic parameters can be obtained. New methods of ac calorimetry [21] and temperature-modulated DSC [22] have been developed for this purpose, and the relaxation time data in the range of 1 s - 1 ks were obtained from the analysis of their

data. The idea of ac calorimetry traces back to 1960s when Sullivan and Seidel [23] have recognized that the heat capacity is a time-dependent quantity. Imaginary part of the heat capacity function should be obtained by analyzing an out-of-phase component of temperature variation of sample in response to a sinusoidal heat wave supplied externally.

It should be noticed, however, that any adiabatic calorimeter can be operated as an ultra-low frequency spectrometer that covers in the time regime of 0.1 ks - 1 Ms. The real virtue of adiabatic calorimetry as dynamic calorimetry lies in the ability to follow such ultra-slow relaxation process in real time. The time domain can be extended to more slow regime depending on the patience of experimentalist and the quality of adiabaticity. Thus the adiabatic calorimetry is facing a turning point with respect to the measuring object from static to dynamic process of thermal behavior observed in condensed matters. The calorimeter directed to this orientation becomes really a thermodynamic instrument.

3.2. Research subjects

IUPAC commission has published recently a series of monograph entitled "The chemistry for the 21st century". One of them deals with chemical thermodynamics [24]. The topics covered in the book include a wide range of substances. They are metals, inorganic as well as organic substances, polymers, and bio-related materials existing in various states of aggregation of the constituents. The wide applicability of thermodynamic study is simply a reflection of the universality of the principles involved in the thermodynamics on which our calorimetric measurements are based firmly. Special emphasis is given in this article to the thermodynamic studies on molecular systems. This is because many of the physical and chemical properties of molecular crystals are very different from those of other solid-state materials.

Molecules of this category are bound to each other through a weak van der Waals interaction. If a molecule contains highly electronegative group such as OH and NH, there must be a delicate balance between the dispersion and hydrogen-bonding forces in the intermolecular interactions. Nature of the latter differs much from the former in its preference directionality. The hydrogen

bonding modifies slightly or drastically the structure and property. Thus a slight change in external variables induces transition from one to another phase. Molecular assembly exhibits a wide variety of states of aggregation of the constituents separated by phase or glass transition. Enantiotropic polymorphism and their mutual transformations are not only interesting from academic point of view but also important in practice.

Some of the molecular crystals transform into mesophases on heating before reaching their fusion temperatures. One of the mesophases is plastic crystal or orientationally disordered crystal (ODC) in which the constituent molecules can take several equi-energetical directions while keeping the translational invariance with respect to the centers-of-masses of the molecules [25]. Onset of the reorientational motion in the ODC phase enhances the apparent molecular symmetry in time- and space-average at each lattice point and results in the formation of isotropic phase with fcc or bcc lattice in general. The phase transition into an ODC phase is accompanied by a large amount of entropy change, hence a large amount of enthalpy of transition. If a molecule has internal-rotational degree of freedom, conformational change of molecule will take place concomitantly at the phase transition. In this case, the disordering process results in a further increase in the enthalpy of transition.

This property can be useful in constructing energy reservoir which absorbs or releases the latent heat while maintaining the constant transition temperature. Our natural resources of fuels are not infinite in the amount. We must save the available energy by employing various energy reservoirs with different levels and efficient heat-exchangers. We must remember the fact that successful commercialization of helium liquefier with reasonable cost became possible by the design and construction of high-efficiency heat exchangers with several stages. Only a few scientists recognize that the most serious and the largest industrial waste is the heat. Manufacturers that require the heat at different levels cannot be independent of each other. Industry in the 21st century should be connected by heat reservoir and heat exchanger in various levels in order to minimize the wasted energy. Calorimetric

determination of the enthalpy change associated with the transition is unavoidable for the research subjects on energy-related materials.

Such a mesophase can be "vitrified" also by avoiding the transformation into an ordered low temperature phase by a rapid cooling [26]. This is analogous to the formation of glasses from liquids by avoiding the crystallization. The states of aggregation of molecules under the equilibrium and non-equilibrium conditions are drawn schematically in Fig. 5. Thus the glassy crystal I can be obtained by rapid cooling of ODC phase and exhibits freezing process (glass transition) in a way quite similar to those of undercooled liquids. If the constituent entities are polar molecules, the freezing out of reorientational motion can be detected by dielectric measurement. On cooling, the orientation polarization ceases to contribute to the dielectric permittivity when the dielectric relaxation time becomes of the order of reciprocal frequency of the external electric field. The crossing takes place either in decreasing temperature at constant frequency or in increasing frequency at constant temperature. The glass transition occurs when the relaxation time becomes about 1 ks, the time scale necessary for a single heat-capacity determination. In a similar way, various glassy states of undercooled liquid crystals can be obtained by rapid cooling of cholesteric, nematic, and smectic phases. The molar heat capacity of *p-n*-hexyloxybenzylidene-*p'*-butylaniline [27] forming a frozen-in smectic phase is given in Fig. 6. Determination of residual entropy is important in clarifying the nature of frozen-in disorder.

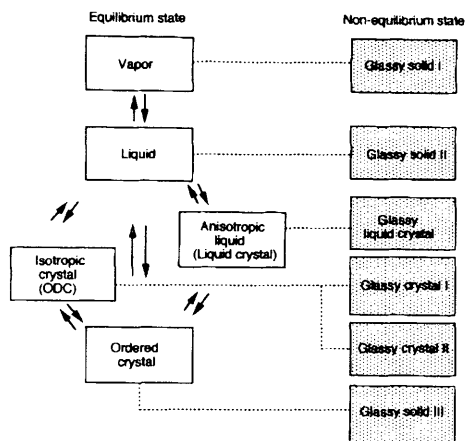

Figure 5 States of aggregation of molecules in equilibrium and non-equilibrium states.

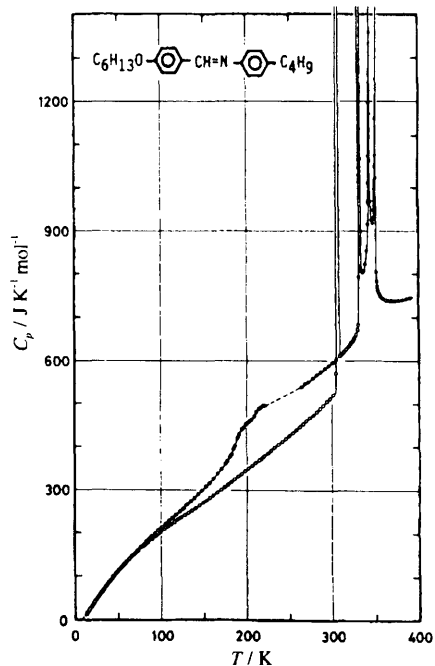

Figure 6 Heat capacity of *p-n*-hexyloxybenzylidene-*p'*-butylaniline.

In glassy crystals II, the freezing out of motion occurs at temperature above the hypothetical transition temperature T_{trs} into an ordered phase. In order to realize the ordered state, the molecules must overcome a potential barrier hindering the motion. The motion will slow down necessarily at low temperatures and freeze out before T_{trs} is reached. This happened in hexagonal ice for which a residual entropy as an indicative of non-ergodic nature was observed [28]. Each water molecule forming four hydrogen bondings can take six orientations, but reorientational motion among them must take place in a highly cooperative way constrained by the ice rules [29]. A minute amount of dopant KOH introduced into the lattice was found to accelerate dramatically the motion by creating a kind of lattice defects which infringe the ice rules. Thus the impurity in the mole fraction of 10^{-4} released the immobilized frozen state to recover the equilibrium state and to reveal the ordering transition at 72 K that has long been hindered kinetically [30]. The experiment by an adiabatic calorimeter with a long-term thermal stability played an essential role in discovering the proton-ordered ice designated as ice XI. The heat capacity of hexagonal ice doped with KOH in the mole fraction of 10^{-4} is shown in Fig. 7.

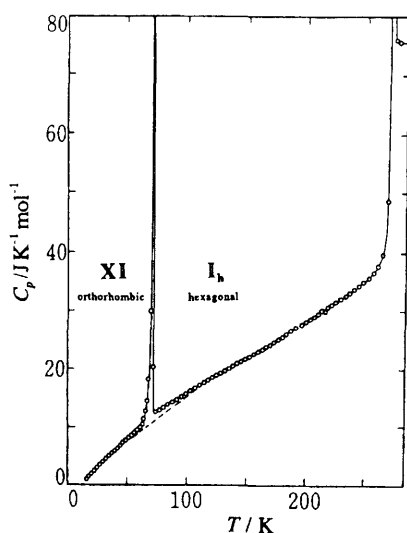

Figure 7 Heat capacity of hexagonal ice I_h doped with KOH in the mole fraction of 10^{-4} .

This observation opens a new realm to be called "doping chemistry" which controls the kinetics of molecular motion by a minute amount of particular and specific impurity [31]. These glassy states of mesophases are intermediate in the nature of disorder between the crystals and the glassy solids. Clarification of the mesophases and their frozen-in disordered states by use of adiabatic calorimetry will be helpful in deepening our fundamental understanding on the glasses or glassy solids that exhibit much more complicated behavior.

More than nineteen millions substances already registered are mostly in crystalline state, but can likely be obtained in principle as glassy solids. Unfortunately, the X-ray or neutron diffraction method grown to a highly sophisticated level is not powerful to the non-crystalline solids compared to the crystalline solids for the structural determination. Important information involved in many Bragg peaks is buried mostly in halo pattern observed for non-crystalline solids. Still, the radial distribution functions derived from the halo with the help of theoretical methods give some important information on the short-range order existing in frozen-in disordered solids. Other experimental methods such as EXAFS are under progress for studies of structures of liquids and glasses, and are expected to play an important role in a future in this field. Materials science that has been initiated since around 1960s was almost

synonymous with the crystal science. Now a new realm of vitreous condensed-matter science is confronting us. These solids must exhibit unique properties which are not easy to anticipate from the knowledge on crystalline materials. Most of the properties of crystals derives from the periodicity of the lattice point on which the constituent entities are located.

Computer simulation grown rapidly in 1980s gives complementary information on the short-range ordered structure in non-crystalline solids. For example, Uchino *et al.* have discussed the origin of sharp peaks designated as D1 and D2 that appear in the Raman spectra of silica glass [32]. They clarified the energetic aspects of various clusters of SiO_2 unit, composed of 4-, 5- and 6-membered rings by using *ab initio* molecular orbital method. Among them, the 4-membered combined with 6-membered ring and the 5-membered combined with 6-membered ring were found to be the origin of the sharp peaks. Both the clusters have rather symmetric structures. The calculated frequencies for the localized symmetric stretching modes of oxygen atoms in the ring agreed well with the observed values. Crystalline silica is composed only of 6-membered rings. Thus fluctuational formation of such small clusters in the melt will hinder the crystallization. Essentially the same conclusion was obtained by molecular dynamics calculation [33]. Such ordered clusters existing in disordered liquids will be the origin of the Boson peaks observed in inelastic neutron scatterings of glasses in general. The nature of short-range order of clusters existing in disordered state as a whole will be discussed in relation to the configurational entropy theory proposed by Adam-Gibbs [35] and the clarification will be surely a key step to the deep understanding of non-crystalline solids.

Glassy solids I can be obtained by deposition of vapor onto a cold substrate. They exhibit likely the glass transition, residual entropy, relaxation, and crystallization processes in essentially the same way as those of glassy solids II (designated traditionally as glasses) that have been obtained by rapid cooling of liquids. However, our calorimetric studies have revealed that the behavior of relaxation below T_g differs much from that of the glasses. The relaxation as revealed calorimetrically through the observation of enthalpy starts

immediately above the temperature at which the vapor was deposited. The amount and the rate of relaxation determined by calorimetric measurement turned out to depend strongly on the temperature of cold substrate. The lower the deposition temperature, the higher the amount and rate of the relaxation [35]. In this vitrification process, the thermal energy of molecules in the vapor is extracted efficiently during rapid condensation in a molecule-by-molecule fashion and the excess energy stored in the deposited solid is generally much higher than that stored in glassy solids prepared by liquid cooling. The process can find out important industrial application in the formation of thin amorphous film, but the basic scientific knowledge on the structure and properties of the glassy solids is quite poor compared with those of crystalline solids.

Glassy solids III can be prepared by solid-state vitrification of crystalline substances by application of hydrostatic pressure or shear stress through ball-milling. One of the current academic topics in this field is the formation of high-density amorphous (hda) ice by pressurization of 1.2 GPa to hexagonal ice at low temperatures [36]. The hda ice was found to transform into low-density amorphous (lda) ice in a reversible way [37] by releasing the pressure or by changing the temperature. The novel phenomenon of "polyamorphism" requires existence of the second critical point in one branch of the liquid-vapor equilibria. A computer simulation has in fact pointed out the critical point in a negative pressure region of liquid water [38]. Still the theoretical discussions are controversial, but the challenging experiment on glassy solids will lead novel and fresh concepts which cannot be reached from the crystal science. It is important to note, however, that each scientist uses his own terminology such as "amorphous", "vitreous", "glassy" and so on. This is an indication of undeveloped nature of this field. These terminology should be clearly defined during the course of advancement. Development of high-pressure calorimeter is specifically desiderative for further study of this intriguing phenomenon.

Solid-state vitrification of metallic system became quite popular in recent years [39]. Binary or multi-component metals can be vitrified by ball-milling. Various alloys with different composi-

tions and properties in crystalline as well as vitreous states have been successfully produced. The method was applied to some molecular crystals to form successfully the glassy solids III [40], as revealed by adiabatic calorimetry. This vitrification method widens the class of glassy molecular solids to the substances which have not enough vapor pressure or undergo thermal decomposition on heating before their fusion temperatures are reached. For example, glucose is described as a good glass-former. However, α -D-glucose crystal decomposes on fusion into various tautomers including α - and β -pyranose conformers in the liquid [41]. A mixture is known to enhance the glass-forming ability than a pure component. By the solid-state vitrification process, only molecular assembly of glucose might be obtained as a glassy solid.

If two kinds of molecular crystal are mixed and vitrified by the ball-milling technique, molecular alloys with different compositions and properties will be formed. In contrast to the metallic systems, formation of solid solution in molecular systems is highly limited under the equilibrium condition [42]. The formation requires the same crystal symmetry, similar molecular shape and property in the two components. Most of the binary solutions of molecular system undergo phase separation on solidification [43]. Now the formation of molecular alloy will be possible under a non-equilibrium condition. The combination of molecular crystals is innumerable and the formation of molecular alloys not only enriches the world of materials science but also finds out many technical applications. Calorimetric investigations are indispensable for clarifying the vitrification process of these exotic solids.

Science of complex systems is a trendy catchphrase used in the application of research fund. In view of the increasing interest and importance in our health, thermodynamic study on biological systems would belong to this category. Likely, study on the glassy states of liquids and mesophases should be included in this category. Chemists and physicists are requested to cooperate for the successful development of this field. Division of physics, chemistry, biology, and others in a branch of science is merely for the educational purpose and not for the research activity.

4. Calorimetry at cryogenic temperatures : Past and future

It was just the beginning of this century when Kamerlingh-Onnes has succeeded to liquefy helium that had been regarded as "the last permanent gas". Two phenomena of superconductivity and superfluidity unexpectedly discovered by his group have been accepted as quantum-mechanical manifestation of some physical quantities which particles possessing light masses are able to exhibit. Both the phenomena are understood essentially as a Bose-Einstein condensation. It is excitingly interesting to learn from the BCS theory that electrons can be a Boson by undergoing a pairing via dynamical coupling with a phonon. The heat-capacity divergence observed for the super-normal fluidity transition of liquid ^4He has led to a new field of critical phenomena in condensed matters, as was described earlier. The discontinuous heat-capacity jump found in some superconducting transitions has led to a new concept of the second-order transition in the classification of phase changes. These monumental works have attracted many scientists to develop a new field of cryophysics [44].

A novel technique called adiabatic demagnetization made it possible to study other quantum effects in cryogenic temperatures as low as several mK. Rotation-vibration levels of a methyl or ammonia group coupled with conversion of nuclear spin is one example of the research subjects to be clarified in the temperature region. These experiments required accumulation of know-how of many cryogenic techniques which are of extremely difficult nature. For this reason, only a limited number of experimental groups with sufficient experiences could engage in the researches of this field.

This sophisticated technique was almost entirely replaced nowadays by ^3He refrigerator [45] or ^3He - ^4He dilution refrigerator [46]. The former produces cryogenic temperatures down to 0.3 K and the latter as low as 5 mK over a long period with much easier operations. Thanks to the rapid growth of cryogenic technology in 1950-1970s, installation of calorimeter workable at very low temperatures became quite popular for thermal characterization of new materials all over the world. These calorimeters are useful to examine any phenomena arising from weak intra- and/or inter-

molecular interactions with low-lying excited levels. The associated heat-capacity anomalies appear clearly at low temperatures where the lattice heat capacity becomes negligibly small. At high temperatures, these anomalous thermal behavior may be easily buried in overwhelmingly large heat capacity arising from various vibrational modes. Even if they were measured accurately, separation of anomalous part from the experimental heat-capacity data is always accompanied by some ambiguity.

Figure 8 shows a schematic drawing of an isoperibol calorimeter with a built-in ^3He evaporator [47]. The calorimeter is covered by a cryostat filled with liquid ^4He at 4.2 K, so that the calorimeter faces always cold surfaces. The whole apparatus is mounted on rubber-dampers for reducing every kinds of mechanical vibration which is a serious source of heat generation to induce spontaneous temperature rise of the calorimetric cell. A part of liquid ^4He is introduced into 1.2 K pot B through a needle valve. Then ^3He gas from external storage tank is liquefied at the ^3He pot. A charcoal adsorption pump C preheated to 30 K is cooled down to 4 K in order to induce adsorption of the ^3He gas. By this forced evaporation, the temperature of the ^3He evaporator cools down to 0.3 K and is kept for about 10 h in a single-shot liquefaction of ^3He .

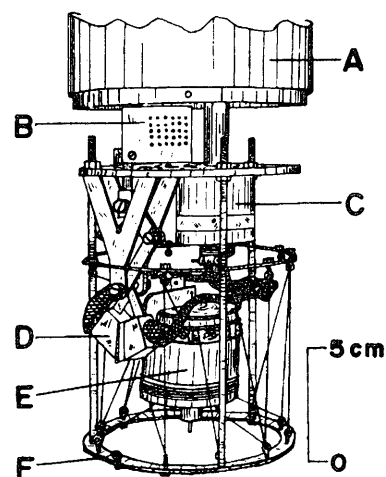

Figure 8 An isoperibol calorimeter for the temperature range 0.3 - 20 K. A, 1.2 K pot (^4He); B, tag for lead wires; C, ^3He evaporator (0.3 K); D, mechanical thermal switch; E, calorimeter cell; F, sample mounting flame.

Any low-temperature adiabatic calorimeter can realize the highest thermal stability at about 100 K by using liquid N₂ as a coolant. Accuracy and precision of the data decrease either at lower or higher temperatures. At higher temperatures, increasing radiation governs natural heat leakage of calorimeter and becomes an important factor that limits the quality of resulting data. At lower temperatures, the heat capacity of a sample decreases rapidly with temperature, being proportional to T^3 ultimately. Again, this makes worse the quality of resulting data. In addition, helium gas as a heat-exchanging medium cannot be used in the cryogenic temperature range below 4 K. Attainment of thermal equilibrium inside the calorimeter cell was established by use of Apiezon or Silicone grease in our case. The use of any solid heat-exchanging media results in a decrease of signal-to-noise ratio of the data. The increased heat capacities of addenda, however, do not induce any serious problem if a sample undergoes a phase transition or exhibits a Schottky heat-capacity arising from low-lying energy scheme at low temperatures.

Figure 9 shows the magnetic heat capacity of (*N,N*-diethyldithiocarbamato)-iron(III) iodide Fe(dtc)₂I, which was obtained by subtracting the lattice-vibrational heat capacity from the total experimental value. The compound is characterized by five-coordination through four sulfur and one chlorine atoms with approximately the square-pyramidal symmetry at the iron site. This crystal undergoes an antiferromagnetic-paramagnetic transition at $T_N = 1.937$ K which is followed by a Schottky-type anomaly arising from a zero-field single ion splitting centered around 12 K. The entropy change associated with the magnetic transition is nearly $R \ln 4$, which indicates that the electronic ground state of the iron ion is uncommonly 4A_2 with spin $S = 3/2$. This spin quantum number is intermediate in magnitude between the high-spin $S = 5/2$ and the low-spin $S = 1/2$ encountered generally in an octahedral symmetry.

Interestingly, the magnetic behavior of the homologous series of halides depends strongly on the kind of counter anions. The corresponding chloride Fe(dtc)₂Cl exhibited a ferromagnetic-paramagnetic transition at $T_c = 2.412$ K. The corresponding bromide Fe(dtc)₂Br exhibited

polymorphism depending on the sample preparation [48]. The sample crystals prepared in non-polar benzene solvent underwent a ferromagnetic transition at $T_c = 1.347$ K, while the sample crystals prepared in polar solvent remained paramagnetic state exhibiting a Schottky anomaly arising from a ferromagnetic dimeric coupling centered at around 0.4 K. The entropy changes due to these anomalies showed the same spin manifold for all the complex compounds. Careful analysis of the heat capacity data allowed us to deduce important information characterizing the magnetic behavior of each complex including the superexchange interaction constant leading to the transition, the coupling constants of the dimeric unit, and the zero-field splitting parameters of Fe(III). These are just one example of organo-metallic complexes formed by innumerable number of combinations among the magnetic ions, the ligands, and the counter anions. Low-temperature heat capacity calorimetry, being entirely free from any selection rules, serves as a powerful tool for elucidation of low-lying energy-level scheme arising from spin-spin interaction, tunnel splitting, and anything else.

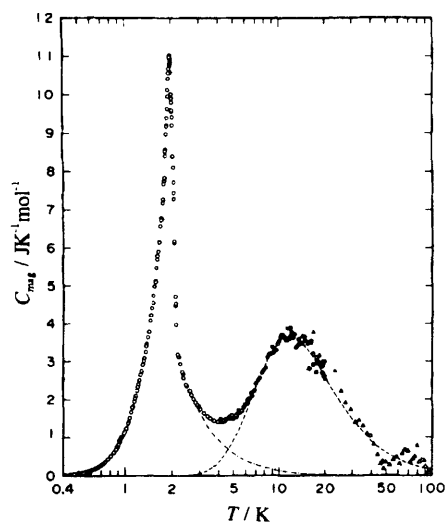

Figure 9 Magnetic heat capacity of (*N,N*-diethyldithiocarbamato)-iron(III) iodide.

Low energy excitation in non-crystalline solids is one of the current topics in condensed matter science [49]. There appear always anomalous heat capacities and thermal conductivities over a temperature range 1-30 K in many non-crystalline solids including amorphous metals, network glasses, molecular glasses, and polymer glasses [50,51]. It

has been stated that the heat capacities of these non-crystalline solids are considerably larger than those predicted by the Debye model, and can be reproduced by addition of a linear term in temperature. Some theoretical models have been proposed to reproduce these experimental data. However, the origin and microscopic mechanism of

the excitation have not been explained successfully. The phenomenon accepted as one of the characteristic properties of non-crystalline solids deserves for clarification by combining various experimental methods. Information from neutron inelastic scattering experiment will be particularly useful in analyzing reliable thermodynamic data.

5. Concluding remarks

"New materials" is one of the horizontal projects proposed by IUPAC body. New materials do not mean necessarily newly synthesized or discovered materials. They include familiar substances of which the properties have not been examined carefully or extensively. It is sure

that unexpected properties and functions useful to our life can be found particularly in non-equilibrium states of well-known substances, because these states of aggregation of molecules were almost out of the scopes of our basic researches up to now.

Acknowledgements

Most of the experimental results reproduced here were obtained at Osaka University when the author was in active services. The author would like to express his sincere thanks to late Professor I. Nitta and Professor S. Seki who introduced him to this field. Thanks are extended to many colleagues and students for their hard works and fruitful discussions.

References

- [1] J. Wilks, *The Third Law of Thermodynamics*, Oxford University Press, Oxford, 1961.
- [2] A. A. Maradudin, E. W. Montroll, G. H. Weiss, *Theory of Lattice Dynamics in the Harmonic Approximation*, Solid State Physics, Supplement 3, Academic Press, New York, 1963.
- [3] N. G. Parsonage, L. A. K. Staveley, *Disorder in Crystals*, Clarendon, Oxford, 1978.
- [4] M. E. Fisher, *Rep. Prog. Phys.* 30 (1967) 615.
- [5] P. Heller, *Rep. Prog. Phys.* 30 (1967) 731.
- [6] M. Tatsumi, T. Matsuo, H. Suga, S. Seki, *Bull. Chem. Soc. Jpn.* 52 (1979) 716.
- [7] H. E. Stanley, *Introduction to Phase Transitions and Critical Phenomena*, Clarendon, Oxford, 1971.
- [8] J. P. McCullough, D. W. Scott (Eds.), *Experimental Thermodynamics, Vol. 1, Calorimetry of Non-reacting System*, Butterworths, London, 1968.
- [9] D. R. Stull, *Anal. Chim. Acta* 17 (1957) 133.
- [10] F. Martin, *Thermochimie*, p. 97, *Colloques internationaux du centre national de la recherche scientifique*, Marseille, 1972.
- [11] K. Kishimoto, H. Suga, S. Seki, *Bull. Chem. Soc. Jpn.* 53 (1980) 2748.
- [12] D. L. Burk, S. A. Friedberg, *Phys. Rev.* 111 (1958) 1275.
- [13] E. F. Westrum, Jr. *Thermochimie*, p. 103, *Colloques internationaux du centre national de la recherche scientifique*, Marseille, 1972.
- [14] Y. Ogata, K. Kobayashi, T. Matsuo, H. Suga, *J. Phys. E; Sci. Instrum.* 17 (1984) 1054.
- [15] T. Matsuo, H. Suga, W. I. F. David, R. M. Ibberson, P. Bernier, A. Zahab, C. Fabe, A. Rassat A. Dworkin, *Solid State Commun.* 83 (1992) 711.
- [16] Y. Miyazaki, T. Matsuo, H. Suga, *Chem. Phys. Lett.* 213 (1993) 303.

- [17]K. Kishimoto, H. Suga, S. Seki, *Bull. Chem. Soc. Jpn.* 46 (1973) 3020.
- [18]H. Suga, T. Matsuo, *Pure & Appl. Chem.* 61 (1989) 1123.
- [19]R. Kohlrausch, *Ann. Phys. (Leipzig)* 12 (1847) 393 ; G. Williams, D. C. Watts, *Trans. Faraday Soc.* 66 (1970) 80.
- [20]S. Brawer, *Relaxation in Viscous Liquids and Glasses*, Am. Ceram. Soc., Columbus, 1985.
- [21]I. Hatta, A. J. Ikushima, *J. Appl. Phys. Jpn.* 20 (1981) 1995 ; N. O. Birge, *Phys. Rev. B* 34 (1986) 1631.
- [22]P. S. Gill, S. R. Sauerbrunn, M. Reading, *J. Thermal Anal.* 40 (1995) 931.
- [23]P. F. Sullivan, G. Seidel, *Phys. Rev.* 173 (1968) 679.
- [24]T. M. Letcher (Ed.) *Chemical Thermodynamics (IUPAC)*, Blackwell, Oxford, 1999.
- [25]J. Timmermans, *J. Phys. Chem. Solids* 18 (1961) 1.
- [26]H. Suga, S. Seki, *J. Non-cryst. Solids* 16 (1974) 171 ; *Faraday Discussion*, No. 69, Roy. Soc. Chem., London, 1980, 221.
- [27]M. Sorai, H. Yoshioka, H. Suga, *Liquid Crystals and Ordered Fluids*, Vol. 4, p.233, Plenum Publ. Corp. N. Y., 1984.
- [28]W. F. Giaque, J. W. Stout, *J. Am. Chem. Soc.* 58 (1936) 1144.
- [29]J. D. Bernal, R. H. Fowler, *J. Chem. Phys.* 1 (1933) 515.
- [30]Y. Tajima, T. Matsuo, H. Suga, *Nature* 299 (1982) 810.
- [31]H. Suga, *J. Chem. Thermodyn.* 25 (1993) 463.
- [32]T. Uchino, T. Yoko, *J. Chem. Phys.* 108 (1989) 8130 ; *Phys. Rev. B* 58 (1998) 5322.
- [33]A. Pasquarell and R. Car, *Phys. Rev. Lett.* 80 (1998) 5145.
- [34]G. Adam, J. H. Gibbs, *J. Chem. Phys.* 43 (1965) 139.
- [35]H. Hikawa, M. Oguni, H. Suga, *Thermochim. Acta* 158 (1990) 143.
- [36]O. Mishima, L. O. Calvert, E. Whalley, *Nature* 310 (1984) 393.
- [37]O. Mishima, *Nature* 384 (1996) 546.
- [38]H. Tanaka, *Nature* 380 (1996) 328.
- [39]R. R. Schwarz, W. L. Johnson, *J. Less-Common Met.* 140 (1988) 171.
- [40]I. Tsukushi, O. Yamamuro, H. Suga, *J. Non-cryst. Solids* 175 (1994) 187.
- [41]J. Fan, C. A. Angell, *Thermochim. Acta* 266 (1995) 9.
- [42]A. I. Kitaigorodsky, *Mixed Crystals*, Springer-Verlag, Berlin, 1984.
- [43]H. A. Oonk, *Phase Theory*, Elsevier, Amsterdam, 1981.
- [44]K. Mendelssohn, *Cryophysics*, Interscience, London, 1960
- [45]G. Seidel, P. H. Keesom, *Rev. Sci. Instrum.* 29 (1958) 606.
- [46]O. V. Lounasma, *Experimental Principles and Methods Below 1 K*, Academic Press, London, 1974.
- [47]N. Arai, M. Sorai, H. Suga, S. Seki, *Bull. Chem. Soc. Jpn.* 50 (1977) 1702.
- [48]M. Yoshikawa, M. Sorai, H. Suga, S. Seki, *J. Phys. Chem. Solids* 41 (1980) 1295 *Chem. Phys. Lett.*, 71 (1981) 54.
- [49]W. A. Phillips, *Rep. Prog. Phys.* 50 (1987) 1657.
- [50]R. C. Zeller, R. D. Pohl, *Phys. Rev. B* 4 (1971) 3027.
- [51]R. B. Stephens, *Phys. Rev. B* 13 (1976) 852.